



## SAFETY WARNING - PLEASE READ CAREFULLY

WARNING - Be certain electrical power is OFF before and during installation and maintenance.

WARNING - Risk of fire and/or electric shock.

WARNING - Risk of fire or electric shock. For install by qualified electrician only. Do not attempt installation if not qualified.

WARNING - Verify that supply voltage is correct by comparing it with the luminaire label information.

WARNING - To prevent wiring damage or abrasion, do not expose wiring to edges of sheet metal or other sharp objects. All wiring connections should be capped with UL approved wire connectors.

WARNING - Wear gloves and safety glasses at all times when removing luminaire from carton, installing, servicing or performing maintenance.

## Maintenance

Perform visual, electrical, and mechanical inspections on a regular basis. The environment and frequency of use should determine this. However, it is recommended that checks be made at least once per year. After turning off the main power, check the electrical system to ensure all connections are clean and tight. Mechanically check that all parts are properly assembled.

## Standard Surface Mount Installation:

1. Turn off all power before attempting installation.
2. Carefully open fixture cover and remove hardware contents. Use caution not to pull ground cable apart from fixture. See Figure A.
3. Depress G13 socket sides, and slide back into the fixture housing. Repeat for other side. See Figure B.
  - 3a. [8 ft. model only] Install brace nut into fixture. See Figure B(1)
  - 3b. [8 ft. model only] Connect tombstone wire harness through the cutout at end of fixture. Connect harnesses. See Figure B(2)
  - 3c. [8 ft. model only] Install locking bracket. See Figure B(3)
4. Wire fixture to line voltage. Direct lines through punch-out access hole on backside of fixture.
5. Attach the included spacer clips to back of fixture. Use included anchors, screws, and washers to affix the fixture to mounting surface. See Figure D.
6. Replace fixture cover and secure with the included hand-screws.

Figure A

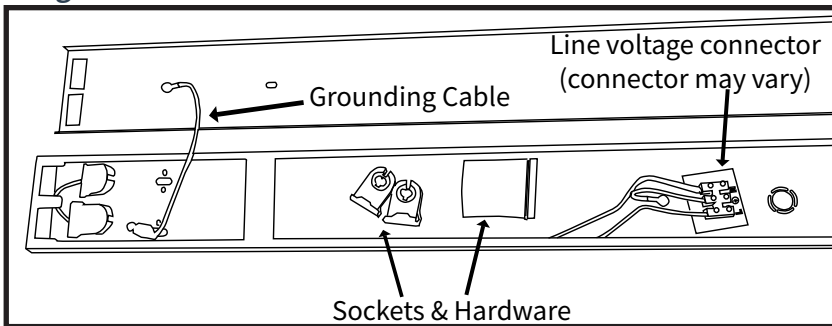

Figure B

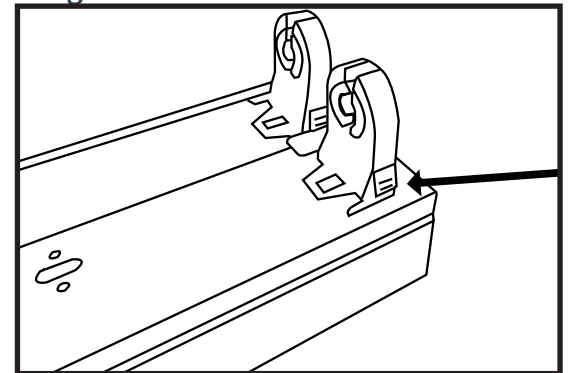

Figure B(1)

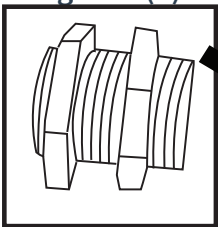

Figure B(2)

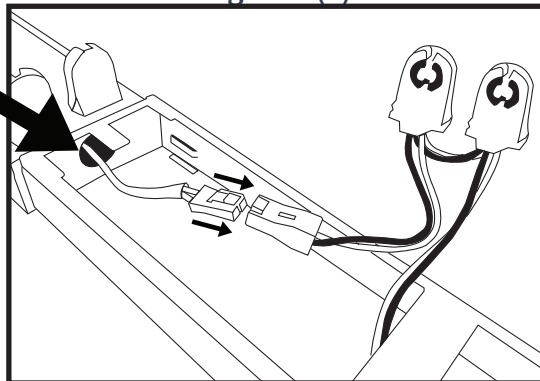

Figure B(3)

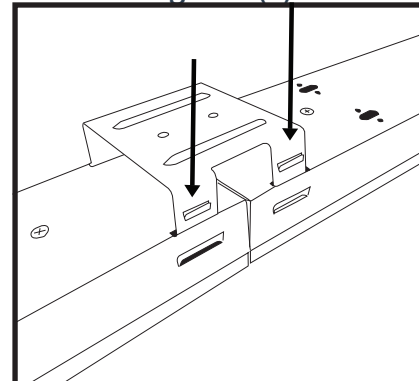

Figure D

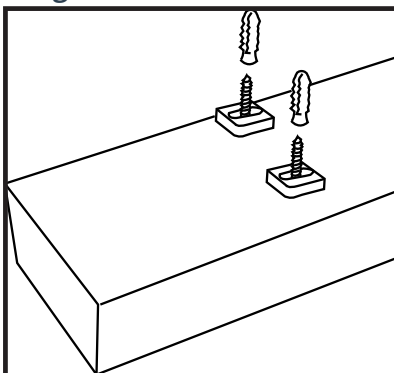

Figure E

